

LOW POWER HIGH STABILITY TCXO

SERIES „TX02520-28-1.0-W-30M-1-CSW“

TCXO SPECIFICATION

PARAMETER AND CONDITIONS	SYMBOL	MIN.	TYP.	MAX.	UNIT	CONDITION
FREQUENCY						
Nominal Frequency	f		30.000		MHz	
FREQUENCY STABILITY AND AGING						
Frequency Stability / Initial Tolerance	f_In.-T.	-1.5	-	+1.5	ppm	Max. after 2 times reflow (ref. to nominal frequency) ^[1]
Frequency Stability vs. Temperature	f_Temp.	-1.0	-	+1.0	ppm	Over -40/+85°C (ref. to +25°C)
Frequency Stability vs. Supply Voltage	f_VDD	-0.2	-	+0.2	ppm	V _{DD} 2.8 VDC ±5%
Frequency Stability vs. Load Variation	f_Load	-0.2	-	+0.2	ppm	Load R/C=(10 kΩ//10pF)±10%
Frequency Stability vs. Aging	f_Aging	-1.0	-	+1.0	ppm	Max. per year (ref. +25°C)
OPERATING TEMPERATURE RANGE						
Operating Temperature Range	T_use	-40	-	+85	°C	
Storage Temperature Range	T_stor	-40	-	+85	°C	
SUPPLY VOLTAGE AND CURRENT CONSUMPTION						
Operable Supply Voltage	V _{DD}	+2.66	+2.8	+2.94	VDC	Specified frequency tolerances are guaranteed for 2.8 VDC ±5%
Current Consumption	I _{DD}	-	-	+2.0	mA	Without load
CLIPPED SINE WAVE OUTPUT CHARACTERISTICS						
Output Level		0.8	-	-	Vp-p	Clipped Sine Wave
Symmetry		40/60	-	60/40	%	GND level (DC cut)
Load Impedance (resistance part)	Load_R	9	10	11	kΩ	
Load Impedance (parallel capacitance)	Load_C	9	10	11	pF	
PHASE NOISE / HARMONICS						
Phase Noise / 1 kHz offset	SSB	-	-	-130	dBc/Hz	Relative to f ₀ offset 1 kHz
Harmonics		-	-	-5	dBc	
STARTUP TIMING						
Startup Time	T_start	-	-	2.0	ms	90% of final V _{out} Level
ORDERING DATA						
RoHS		Lead free and RoHS compliant				
Delivery Form		Tape & Reel / 3.000 pcs per reel				
Ordering Code		TX02520-28-1.0-W-30M-1-CSW				
Marking		Line 1 = Model code + Frequency Line 2 = Logo + Date code (xxx)				
Customer P/N		PETERMANN-TECHNIK P/N				
		OEU90010131				

Note:

1. Please leave after reflow in 2 hours or more at +25°C, reflow solder process can shift the frequency ±1.5 ppm max. If frequency get shifted by reflow process, frequency do not come back to initial value before reflow solder process.
2. Reference Temperature for all parameters: +25°C
3. Do not use ground-line below oscillator.
4. Do not use cleaning baths operating at ultrasonic frequencies or ultrasonic welding processes.

DIMENSIONS AND PATTERNS

PACKAGE SIZE – DIMENSIONS (UNIT:MM)
 2.5 X 2.0 X 0.8 MM

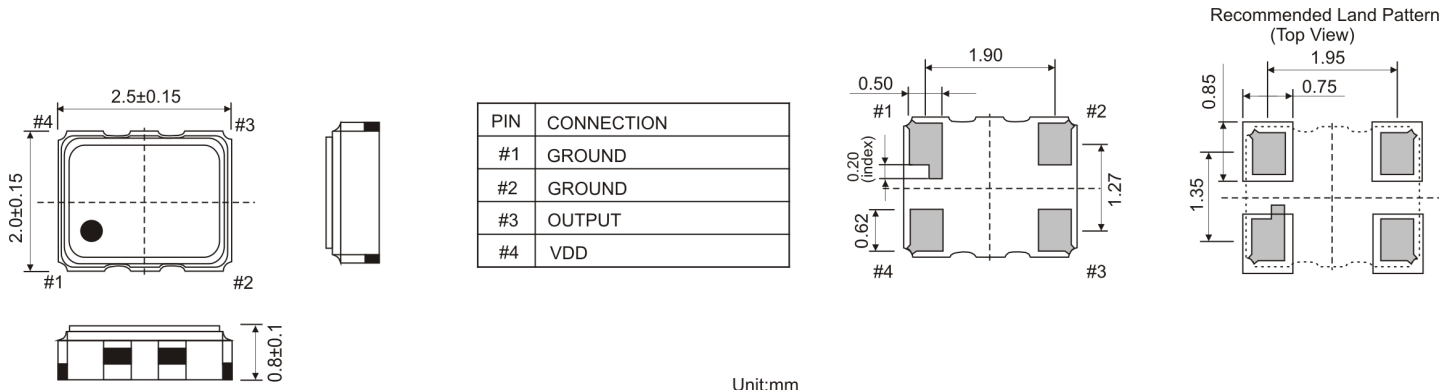

TEST CIRCUIT CLIPPED SINE WAVE OUTPUT

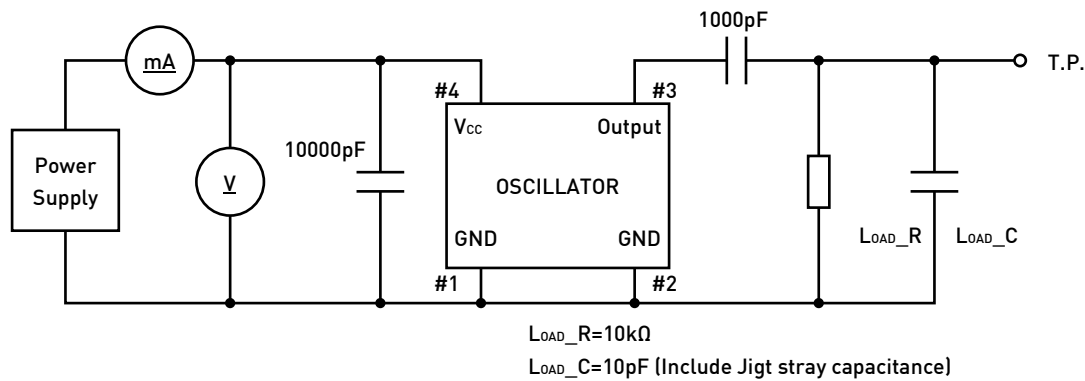

REFLOW SOLDER PROFILE

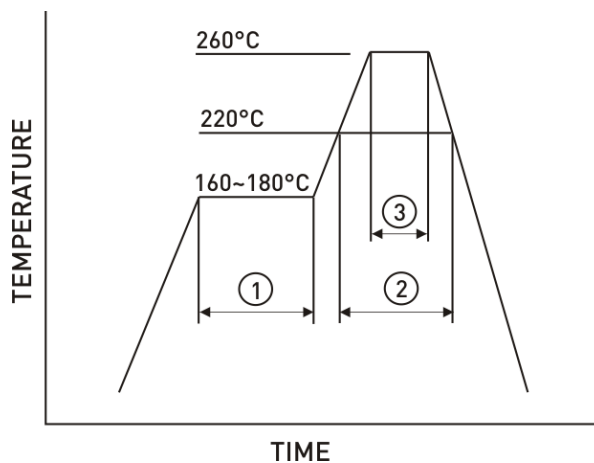

①	Preheat	160~180°C	120sec.
②	Primery heat	220°C	60sec.
③	Peak	260°C	10sec. max.



PREMIUM QUALITY BY PETERMANN-TECHNIK



OUR COMPANY IS CERTIFIED ACCORDING TO ISO 9001:2015 AND 14001:2015

THIS IS FOR YOU TO ENSURE THAT THE PRINCIPLES OF QUALITY MANAGEMENT ARE FULLY IMPLEMENTED IN OUR QUALITY MANAGEMENT SYSTEM AND QUALITY CONTROL METHODS ALSO DOMINATE OUR QUALITY STANDARDS.